

## CHQ Adaptor INSTALLATION MANUAL (CHQ-ADAPTOR)

The CHQ-ADAPTOR is designed to allow the “Smart-Fix” range of CHQ Modules to be housed in existing enclosures originally designed for the first generation CHQ-OEM Modules by modifying the ‘footprint’ of the unit.

When disassembling the “Smart-Fix” CHQ Module in preparation for mounting onto the Adaptor please be aware that the device features a printed circuit board (PCB) which contains electro-static sensitive components. Observe precautions for handling these components to avoid damage to the unit.

### ASSEMBLING THE UNIT

Locate one of the retaining clips on the side edge of the PCB cover on the CHQ Module.

- Using a small screw driver, carefully push the clip inwards whilst lifting the PCB cover upwards (see Fig 1). When the PCB cover is removed, the PCB will be visible.
- Hold the PCB by the plastic terminal blocks (see Fig 2) and carefully remove from the CHQ Module housing.
- Place the PCB into the CHQ Adaptor ensuring the loop cable connectors sit within the correct cut-away at the bottom edge of the raised section of the adaptor (see Fig 3 overleaf).
- Take the PCB cover originally removed from the CHQ Module and position over the PCB.
- Ensure the plastic lugs on the inside edge of the PCB cover (opposite end to the holes for the retaining clips) are engaged in their respective holes. The retaining clips on the adaptor will now be lined up with their corresponding holes on the PCB cover (see Fig 4 overleaf).
- Push the two parts together until the retaining clips engage.
- Wire the CHQ Module as per the installation instructions.

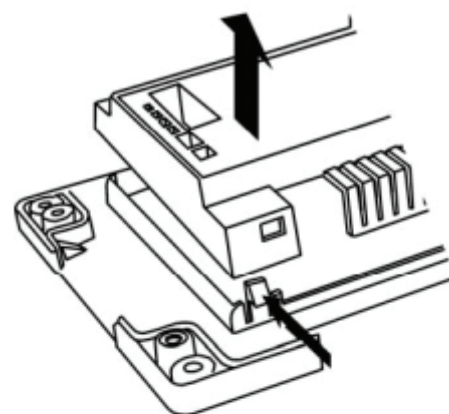

Fig 1

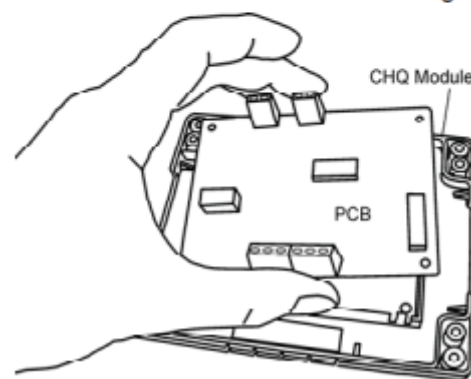

Fig 2

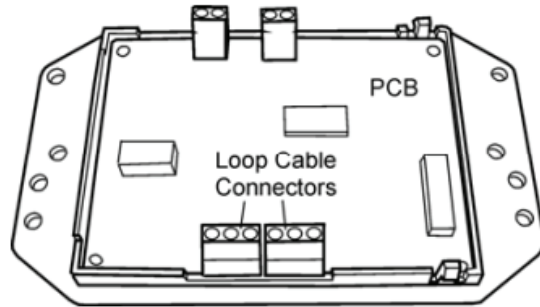

Fig 3

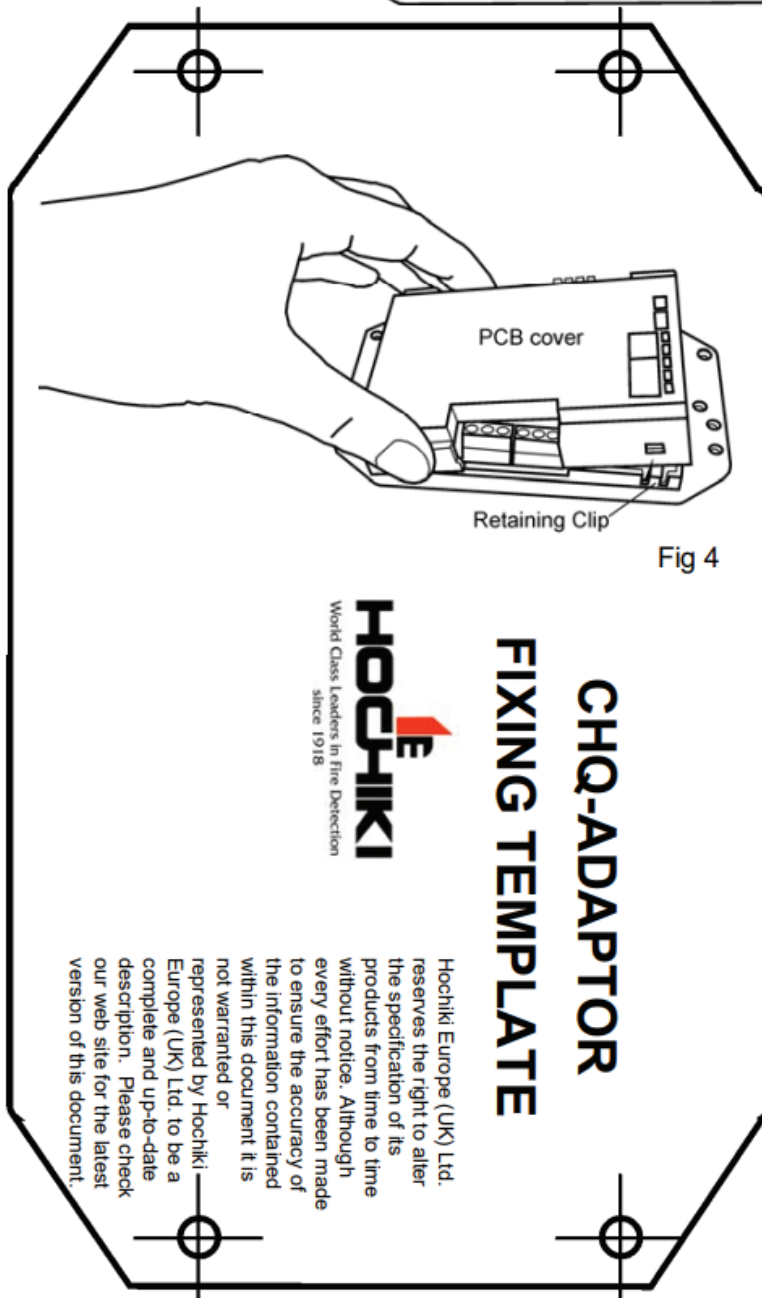

Fig 4

## CHQ-ADAPTOR FIXING TEMPLATE

**HOCHIKI**  
World Class Leaders in Fire Detection  
since 1918

Hochiki Europe (UK) Ltd. reserves the right to alter the specification of its products from time to time without notice. Although every effort has been made to ensure the accuracy of the information contained within this document it is not warranted or represented by Hochiki Europe (UK) Ltd. to be a complete and up-to-date description. Please check our web site for the latest version of this document.